

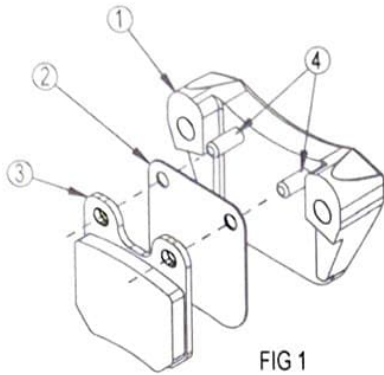

CONVENTIONAL FRONT CALIPER ASSEMBLY INSTRUCTIONS

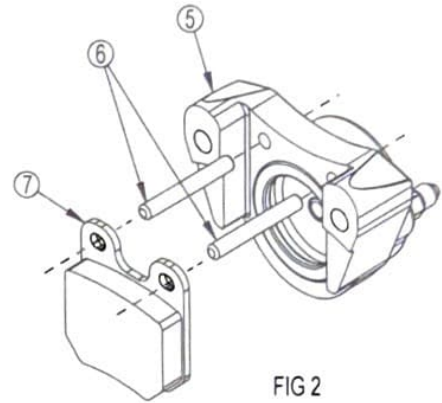

Step 1 - Install the insulator plate (2) and outer brake pad (3) by sliding them onto the brake pad pins (4) located in the outer caliper (1), as shown in Fig 1.



Step 2 - Install the brake pad pins (6) into the inner caliper (5) by sliding them through the holes located in the caliper as shown in Fig 2. Next, slide the inner brake pad (7) onto the brake pad pins (6) as shown in Fig 2.

Step 3 - Install the caliper bolt washers (10) over the caliper bolts (11) and slide the bolts through the floater bracket (9), bracket spacers (8), and the inner caliper (5) as shown in Fig 3.

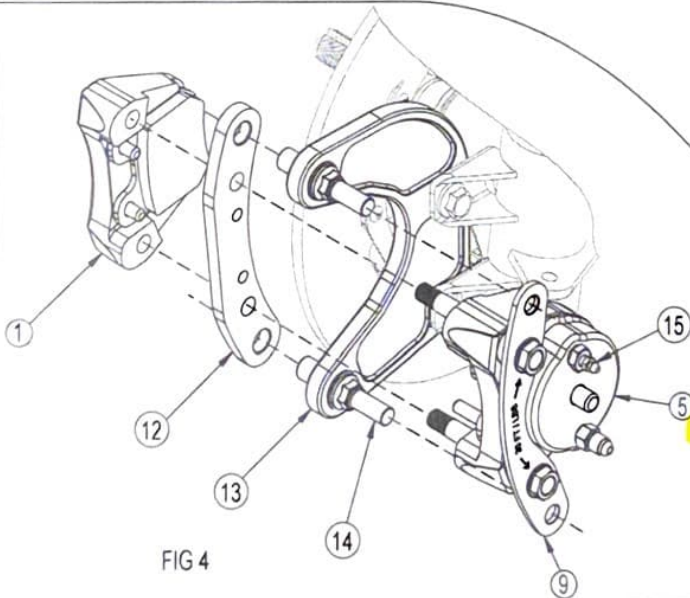
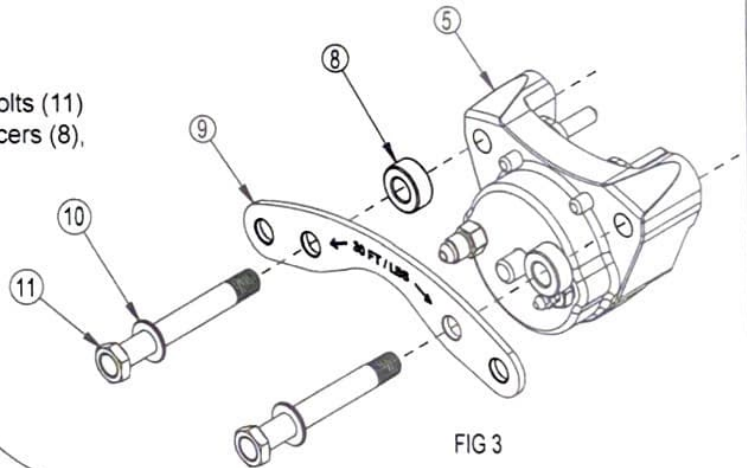

Step 4 - Slide the floater bracket (12) onto the floater stand (14). Next, slide the floater bracket (9), located on the inner caliper assembly onto the floater stand (14) as shown in Fig 4. Thread bridge bolts (11) into the outer caliper (1) and torque them 25-30 ft/lbs. Make sure the bleed screw (15) is in the upper hole of the caliper (5). If not, reverse caliper from the other side of the car.

NOTE: When the pin in the center of the caliper is almost flush with the caliper housing, its time to change the pads. Do not operate car beyond that point, or fluid loss and brake failure will result. When worn, the inner caliper pad can be resurfaced to become a new outer pad.